

Flux growth and characterization by X-ray topography of rare earth arsenates

S. H. SMITH, G. GARTON

Clarendon Laboratory, University of Oxford, UK

B. K. TANNER, D. MIDGLEY

Department of Physics, University of Durham, UK

Optically clear crystals of rare earth arsenates, RAsO_4 , have been grown from $\text{Pb}_2\text{As}_2\text{O}_7$ flux by slow cooling and recovered by a hot-pouring technique. X-ray anomalous transmission topography has shown that the crystals are of good quality, and their perfection is compared with that of RVO_4 crystals grown by a similar method. The surfaces of crystals recovered by hot-pouring were found to contain higher densities of precipitates than those recovered by dissolution of the flux.

1. Introduction

The rare earth arsenates RAsO_4 ($\text{R} = \text{Sm}$ to Lu) have the tetragonal zircon (ZrSiO_4) structure. Like the rare earth vanadates, RVO_4 ($\text{R} = \text{Tb}$ to Lu), the arsenates are transparent and of interest on account of their magnetic properties at low temperatures. In particular GdAsO_4 , TbAsO_4 and DyAsO_4 exhibit antiferromagnetic transitions, while TbAsO_4 , DyAsO_4 and TmAsO_4 undergo cooperative Jahn-Teller distortions [1]. The growth of RAsO_4 [2] and rare earth doped YAsO_4 [3] from $\text{Pb}_2\text{As}_2\text{O}_7$ flux has been reported, but only needle- or lath-shaped crystals were obtained. Crystals up to 10 mm in length and 2 mm square in cross-section were required for a variety of studies [4, 5], and since such crystals of both RVO_4 and RPO_4 have been grown from $\text{Pb}_2\text{V}_2\text{O}_7$ and $\text{Pb}_2\text{P}_2\text{O}_7$ fluxes respectively by prolonged slow cooling [6] it was proposed that comparable crystals of RAsO_4 might be obtained by a similar method. However, as $\text{Pb}_2\text{As}_2\text{O}_7$ is highly toxic and appreciably more volatile than either $\text{Pb}_2\text{V}_2\text{O}_7$ or $\text{Pb}_2\text{P}_2\text{O}_7$, it was desirable for the crystal growing furnace to be protected from contamination, for the slow cooling programme to be followed by hot-pouring without the intermediate handling of crucibles, and for experiments to be performed under conditions of good ventilation. A hot-pouring facility was necessary because RAsO_4 crystals are fragile and are liable to fracture unless separated

from the flux prior to solidification. The construction of a simple apparatus which satisfied these requirements is described in this paper.

A programme of assessment by X-ray topography was carried out on the crystals obtained from a series of growth experiments. The effects of changes in experimental procedures and growth conditions were thereby determined, and the results are reported.

2. Crystal growth apparatus

The apparatus which was constructed to enable the growth of crystals to be followed by hot-pouring *in situ* is shown in Fig. 1. A sillimanite tube, 1 m in length and 14 cm in diameter, was supported at each end by a pair of wheels which were mounted on a scissor jack. The tube passed through a rectangular chamber furnace and was situated between two arrays of Crusilite elements. The ends of the chamber were blocked by shaped plugs of alumina brick but sufficient clearance was provided for the tube to be rotated easily about its axis.

Since the tube was situated near the bottom of the chamber, a small vertical temperature gradient existed within the tube when the furnace was hot. The magnitude of the gradient depended on the position of the tube and could be varied by adjusting the height of the jacks. The temperature of the furnace was regulated by an Ether controller and

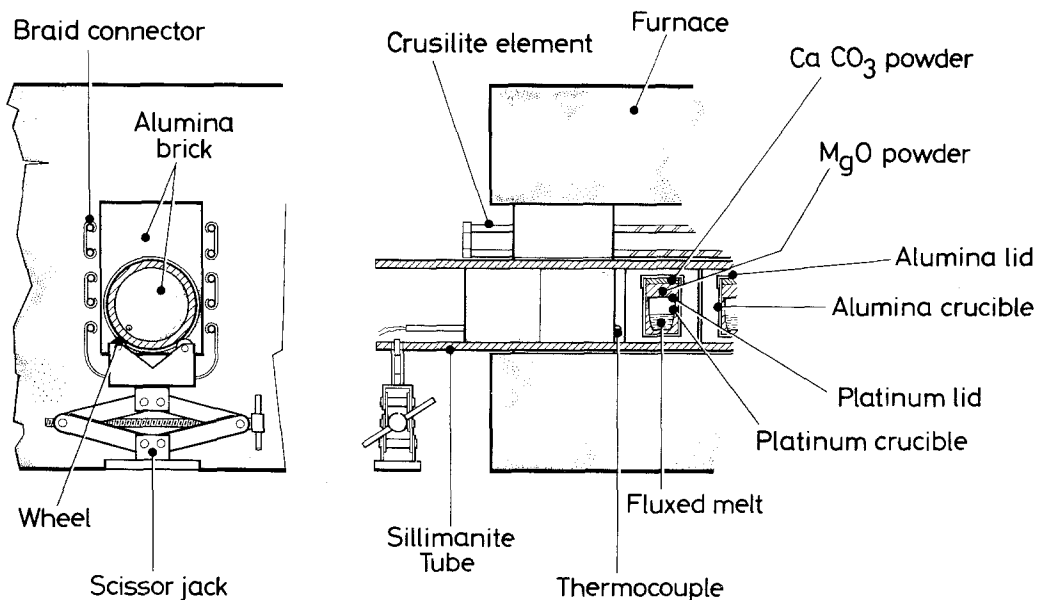

Figure 1 Schematic diagram of the furnace with the facility for hot-pouring *in situ*.

the cooling programme was provided by a Eurotherm programmer.

The furnace was enclosed by a metal hood which was connected to an extractor fan. Access to the tube was provided by small, detachable panels at each end of the hood.

3. Crucibles and chemicals

The crucibles were of pure platinum, of 20 cm³ or 50 cm³ capacity and 0.5 mm in wall thickness. Each crucible was provided with a closely fitting flanged lid. The chemicals were: Hopkin and Williams "pure" Pb₂As₂O₇, Rare Earth Products 99.9% pure rare earth oxides, B.D.H. calcined CaCO₃ and 'heavy' MgO.

4. Crystal growth

Starting from published data [2, 3] a number of trial experiments were performed with 23 g Pb₂As₂O₇ and 1 to 2.5 wt% R₂O₃ in 20 cm³ platinum crucibles. The crucibles were placed either singly or in pairs, one above the other, in Morgan alumina crucibles and the spaces around them were filled with "heavy" MgO powder. A layer of CaCO₃ powder was then added and an alumina lid was placed over each crucible. The powders were provided to react with any flux, as vapour or liquid, which might escape from the platinum crucibles at high temperatures.

In a typical experiment, two alumina crucibles were placed in cylinders of Morgan M.I. 28 firebrick and introduced into the furnace, as shown in Fig. 1. The furnace was then heated until the crucibles were at about 1330° C, at which temperature the vertical temperature gradient at the crucibles was about 1.5 K cm⁻¹, the top of each crucible being hotter than the base. After a soak period of about 4 h the furnace was cooled at 1 K h⁻¹. When the crucibles were at about 950° C, the furnace tube was rotated through 180° to invert them and so pour the flux from the crystals. Finally the furnace was cooled to room temperature at about 100 K h⁻¹.

When the melts were examined it was found that evaporation losses were from 20 to 40 wt% and that hot-pouring had not occurred. The latter was explained by reference to the PbO-As₂O₅ phase diagram [7] on the basis that the melting point of the flux had increased from 802° C [7], as a result of the preferential loss of As₂O₅, to values above that at which the crucibles were inverted.

The flux was dissolved in hot dilute (1:3) HNO₃ and the crystals were recovered. It was found that melts which initially contained less than 2 wt% R₂O₃ generally yielded crystals less than 1 mm in width, but that more concentrated melts produced a few larger crystals. For example, a melt which

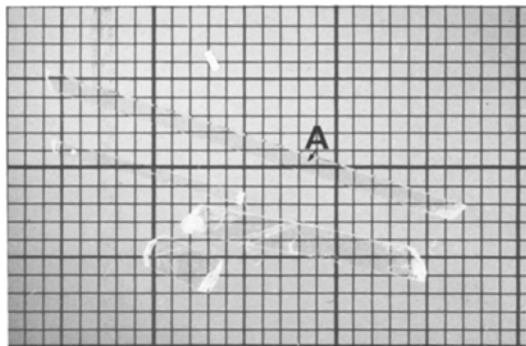

Figure 2 TmAsO₄ crystals from a melt containing 2.5 wt% Tm₂O₃ and recovered by dissolution of the flux. (1 mm grid).

contained 2.5 wt% Tm₂O₃ produced the crystals shown in Fig. 2. These had grown at the surface and were recovered intact, although other crystals which had grown beneath the surface were mostly cracked or broken.

Subsequent experiments were performed with melts which contained 2.5 to 5 wt% R₂O₃. These were cooled from 1400 to 1050° C and the crucibles were inverted. Since the latter temperature is above the melting point of Pb₃As₂O₈ which, at 1042° C, is the highest point in the PbO–As₂O₅ phase diagram [7] no difficulties were experienced in hot-pouring the flux and the majority of crystals were recovered intact. The best results were obtained from melts which contained 3.5 to 4 wt% R₂O₃.

Crystals of GdAsO₄, DyAsO₄, TmAsO₄, LuAsO₄, and YAsO₄ doped with Gd were grown from 70 g melts in 50 cm³ crucibles. Optically clear rods up to 10 mm × 2 mm × 2 mm, and

plates up to 5 mm × 4 mm × 0.2 mm were obtained. Some plates of TmAsO₄ are shown in Fig. 3. As has been observed in the growth of RVO₄ and RPO₄ [6], the crystals tended to increase in thickness as the radius of the rare earth ion decreased.

5. Assessment of crystal perfection by X-ray topography

A considerable number of crystals were examined by X-ray topography. The topographs were taken on a Lang camera using MoKα₁ and AgKα₁ radiation and recorded on Ilford L4 Nuclear Emulsion. In the first instance all crystals were examined in the as-grown state after all traces of residual flux had been removed. The whole of each crystal was then examined, without either cutting or polishing, as described in previous studies on flux-grown rare earth complex oxides [8–10]. As in the case of RVO₄ [8], substantial transmitted intensity was found in the diffracted beam from crystals up to 1 mm thick. This “anomalous transmission” is found only in highly perfect crystals, and so it was evident from the very first topographs that crystals of perfection comparable to that of RVO₄ had been grown. Crystal defects, such as dislocations, destroy the anomalous transmission and appear on the topographs as regions of reduced intensity. In this paper the anomalous transmission topographs are printed as negatives so regions of enhanced intensity appear light against a dark background. Details of the growth of the crystals shown in the topographs are given in Table I.

In early experiments, crystals were separated from the flux by dissolving the latter in acid. The long crystal of TmAsO₄ marked “A” in Fig. 2 was

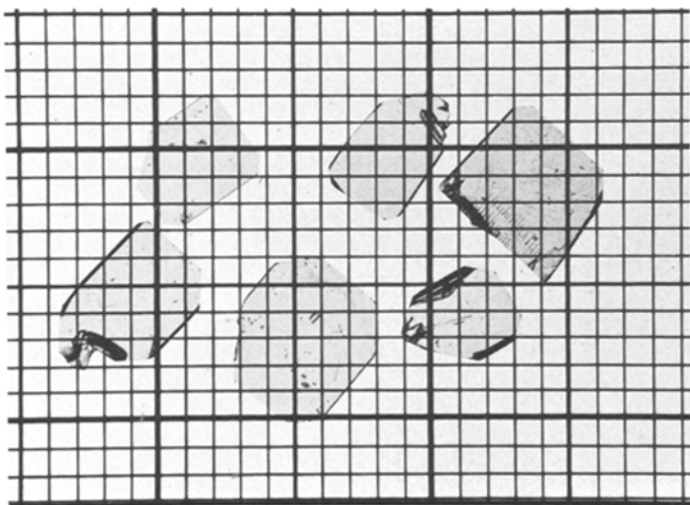

Figure 3 TmAsO₄ plates grown from a melt containing 3.5 wt% Tm₂O₃ and recovered by hot pouring. (1 mm grid).

TABLE I Growth data for RAsO₄ crystals

| Crystal | Initial composition | Growth programme | Hot-poured | Remarks | Topograph |
|--|--|--|------------|--|------------------|
| TmAsO ₄ | 2.5 wt% Tm ₂ O ₃ in 23 g flux | 1350° C to below 800° C at 1 K h ⁻¹ | No | Large crystal at surface Recovered from the body of the melt | Fig. 4 Fig. 5 |
| DyAsO ₄ | 2.5 wt% Dy ₂ O ₃ in 23 g flux | 1380° C to about 860° C at 1 K h ⁻¹ | No | Cooling programme erratic, controller hunting | Fig. 6 |
| GdAsO ₄ | 3.5 wt% Gd ₂ O ₃ in 92 g flux | 1380 to 1080° C at 1 K h ⁻¹ | Yes | Flux loss 33% of melt | Fig. 7a |
| Lu _{0.98} Tm _{0.02} AsO ₄ | 3.5 wt% R ₂ O ₃ in 68 g flux | 1400 to 1290° C and then 1300 to 1050° C, both at 1 K h ⁻¹ | Yes | Flux loss 10% of melt (Welded lid) | Fig. 8 |

recovered in this way from the surface of the melt, where it had apparently floated. This crystal is 0.7 mm thick and a topograph of part of it is shown in Fig. 4. It can be seen that the crystal is of excellent quality, for the anomalous transmission is high and the material appears to be effectively dislocation-free.

The only defects which can be identified are precipitates showing black-white contrast. This contrast is typical of defects which lie close to the surface, and from the sense of the contrast we conclude that the surrounding lattice is compressed as in crystals of RVO₄ and RPO₄ [8, 9]. No imperfect layer or "skin" of the type exhibited by crystals of RVO₄ [8] can be detected, and the density of precipitates is very low. The crystal is in fact superior in quality to any other RAsO₄ crystal grown to date and is a good example of beginner's luck.

A topograph of a crystal which was recovered from beneath the surface of a melt is shown in Fig. 5. In this example, it can be seen that the crystal is of good quality with relatively few surface precipitates. However a substantial number of dislocation lines can be identified, and we presume that these dislocations, which do not lie along crystallographic directions, resulted from plastic deformation as the flux solidified.

The importance of a carefully controlled cooling programme is illustrated in Fig. 6. This shows a crystal of DyAsO₄ from a batch which grew during an erratic cooling programme when a fault developed in the temperature control system. Many inclusions are evident throughout the crystal volume, substantial polishing failed to remove the contrast, and many long, straight dislocations parallel to the

c-axis are visible. Other specimens from this batch exhibited similar long, straight dislocations, which were never observed in crystals from batches obtained after a normal, unperturbed cooling programme.

In hydrothermally-grown calcite, both screw and edge dislocations were found to have nucleated following abrupt perturbations in the growth conditions [11]. The dislocations in DyAsO₄ shown here also appear to result from perturbations in the growth conditions. This hypothesis is supported by the fact that the dislocation configuration is very similar to that observed in RVO₄ crystals grown by pulling from the flux [12], and totally unlike that associated with plastic deformation in RPO₄ [9]. In the 004 reflection another set of dislocations running parallel to [100] was observed, while the set running parallel to [001] was invisible. All dislocations are thus of edge orientation.

In later experiments, crystals were recovered from the flux by hot-pouring, and a topograph of a crystal of GdAsO₄ obtained in this way is shown in Fig. 7a. There are no dislocations to be seen, but the surface of the crystal is covered with precipitates. The topograph is remarkably similar to one of a crystal of TbVO₄, shown in Fig. 7b, which was grown from Pb₂V₂O₇ flux and also recovered by hot-pouring.

All RAsO₄ crystals recovered by hot-pouring exhibited a similar high density of precipitates at their surfaces, and the effect is attributed to small drops of flux remaining on the crystals after their separation from the bulk of the liquid. High densities of surface precipitates have also been observed in NiF₂ crystals [13], and it appears that the effect

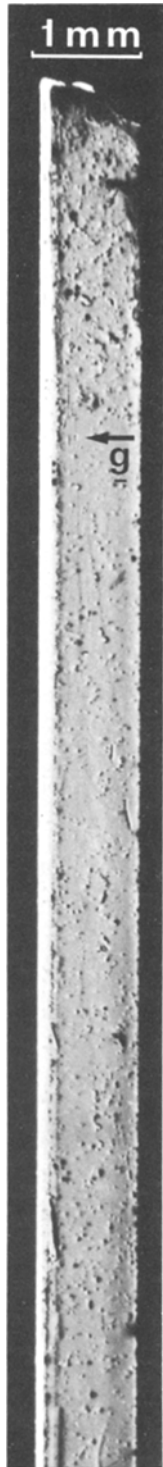

Figure 4 X-ray topograph of the TmAsO_4 crystal marked "A" in Fig. 2. Note the absence of defects in the bulk of the crystal and the low density of surface precipitates. ($\text{MoK}\alpha_1$ radiation, 200 reflections, c -axis vertical in this and other topographs).



Figure 5 X-ray topograph of a TmAsO_4 plate recovered from the body of a solidified melt. Note the non-crystallographically oriented defects, the good anomalous transmission, and the few surface defects. ($\text{MoK}\alpha_1$ radiation, 200 reflection).

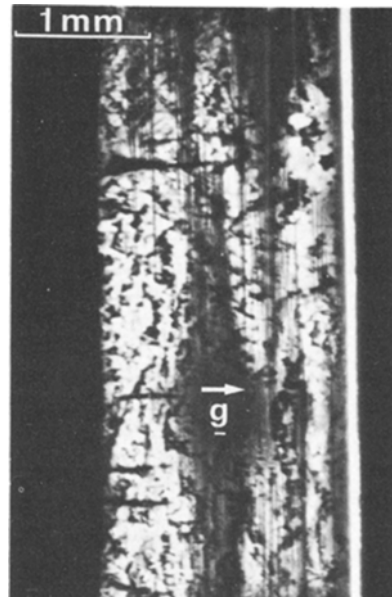

Figure 6 X-ray topograph of a DyAsO_4 crystal grown during a poorly controlled cooling programme. Note the many dislocation lines running parallel to the c -axis. ($\text{MoK}\alpha_1$ radiation, 200 reflection).

is characteristic of crystals recovered by hot-pouring.

There was no evidence that hot-pouring was responsible for any other defects, and so it was subsequently carried out in all routine growth experiments. Crystals were thus recovered relatively

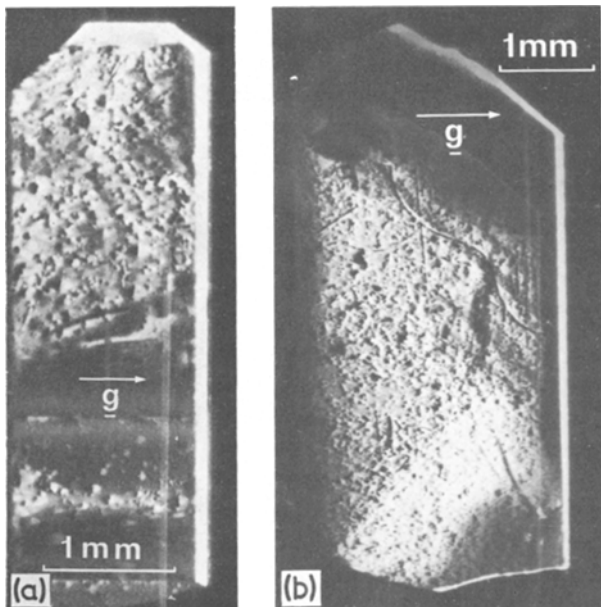

Figure 7 X-ray topographs of crystals recovered by hot-pouring. (a) GdAsO_4 (b) TbVO_4 . Note the characteristic defect configuration. ($\text{MoK}\alpha_1$ radiation, 200 reflection).



Figure 8 X-ray topograph of a $\text{Lu}_{0.98}\text{Tm}_{0.02}\text{AsO}_4$ crystal grown in a welded crucible. ($\text{AgK}\alpha_1$ radiation, 200 reflection).

quickly, and the risks that dislocations would be introduced or fractures occur as a result of the solidification of the flux were largely avoided.

The perfection of mixed RAsO_4 crystals containing two rare earth ions was found to be comparable with that of crystals containing only one, as in the case of RVO_4 [8]. This is demonstrated by the topograph of the $\text{Lu}_{0.98}\text{Tm}_{0.02}\text{AsO}_4$ crystal shown in Fig. 8. The crystal was grown in a crucible to which a lid had been welded, and so the loss of flux by evaporation was relatively small. It was thus evident that crystal perfection was also not significantly affected by the reduction in the rate of evaporation. Furthermore, the insertion of a small, *positive* step into the cooling programme (Table I) was shown not to lead to the introduction of a large number of dislocations. Such steps could thus be used to control the number, and hence the size, of crystals obtained by spontaneous nucleation in future experiments without seriously affecting the dislocation density.

6. Conclusions

Quite large RAsO_4 crystals of very good quality have been grown from $\text{Pb}_2\text{As}_2\text{O}_7$ flux by slow cooling. The recovery of crystals by hot-pouring largely avoided the risks of plastic deformation or fracture as the flux solidified and enabled even

very fragile specimens to be obtained intact. Hot-pouring does, however, introduce defects in the form of precipitates at the surfaces. The perfection of RAsO_4 crystals was shown to be comparable with that of RVO_4 crystals [8] and to be considerably better than that of RPO_4 crystals [9] when grown under similar conditions.

Acknowledgements

The authors wish to thank Mrs B. M. Wanklyn for helpful discussions, Mr B. J. Garrard and Mr P. Clack for the construction of apparatus, and Mr G. Gwynn for technical assistance. The work was supported in part by the Science Research Council.

References

1. G. A. GEHRING and K. A. GEHRING, *Rep. Prog. Phys.* **38** (1975) 1.
2. R. S. FIEGELSON, *J. Amer. Ceram. Soc.* **50** (1967) 433.

3. W. H. HINTZMANN and G. MÜLLER-VOGT, *J. Cryst. Growth* **5** (1969) 274.
4. J. E. BATTISON, A. KASTEN, M. J. M. LEASK, J. B. LOWRY and K. J. MAXWELL, *J. Phys. C* **9** (1976) 1345.
5. J. E. BATTISON, M. J. M. LEASK, J. B. LOWRY and A. KASTEN, *J. Phys. C* **9** (1976) 2295.
6. S. H. SMITH and B. M. WANKLYN, *J. Cryst. Growth* **21** (1974) 23.
7. E. M. LEVIN, C. R. ROBBINS and H. F. McMURDIE, "Phase Diagrams for Ceramists", (American Ceramic Society Inc., Columbus, Ohio, 1964) Fig. 286.
8. B. K. TANNER and S. H. SMITH, *J. Cryst. Growth* **28** (1975) 77.
9. *Idem, ibid* **30** (1975) p. 323.
10. B. M. WANKLYN, D. MIDGLEY and B. K. TANNER, *ibid* **29** (1975) 281.
11. F. LEFAUCHEUX, M. ROBERT and A. AUTHIER, *ibid* **19** (1973) 329.
12. S. H. SMITH, G. GARTON and B. K. TANNER, *ibid* **23** (1974) 335.
13. M. SAFA, private communication.

Received 30 May and accepted 8 July 1977.